

ENGINE SYSTEM

- Isuzu® 4LE2TAGV08
- Diesel fueled
- EPA Final Tier 4
- 4 cylinder
- 2.2 L displacement
- Power @ 1,800 rpm – HP (kW):
 - Prime: 36.2 (27.0)
 - Standby: 40.2 (30.0)
- Air filter: Dry-type cartridge

Fuel System

- Polyethylene tank
- Tank usable fuel volume: 51.4 US gal (194.5 L)
- Fuel consumption – gph (Lph):
 - Lights only: 1.05 (3.97)*
 - 100% load: 2.1 (7.8)*
- Exterior fill port diameter: 3.5 in (89 mm)
- Fuel filter with replaceable element
- Maximum run time (lights only): 48 hr

Cooling System

- Liquid cooled

Lubrication System

- Oil filter: Full flow, spin-on type
- 500-hr service interval*

**Data based on engine manufacturer and field test data after 100-hr engine break-in period. Actual results may vary, according to factors such as age and maintenance of equipment, environmental conditions, and fuel density. For fuel and maintenance recommendations, see owner's manual.*

GENERATOR

- 60 Hz engine/generator
- Marathon Electric® brushless
- Up to 20 kW output (standby)
- 120/240 VAC, 167/83 A
- \pm 1% automatic voltage regulation (electronic)

CONTROLS

- Deep Sea® L401 Advanced Controller
- Designed specifically for mobile lighting applications
- Dusk-to-dawn programming based on location
- Seven-day scheduler automatically starts and stops the unit each day
- Programmable service reminders for custom alerts
- Comprehensive warnings protect the operator and equipment
- Event history to monitor fleet
- Large, easy-to-read, backlit color display
- Heated display with ability to operate in cold weather
- IP65 water ingress rating



Picture shown may not reflect actual configuration.

LIGHTING

- Four 320 W LED luminaires
 - Lm/fixture: 47,000
 - Total lm: 188,000
- Efficiency: 147 lpw
- Coverage at 0.5 ft-c or more: 28,040 ft² (2,605 m²)
- Aluminum and polymer housing
- IP68 LED modules; IP65 rated drivers
- Fixture-mounted drivers
- Friction disc mounting for tool-free positioning

ELECTRICAL SYSTEM

- 100 A start limit breaker (ensures no-load condition exists at start-up)
- Individual floodlight circuits with 5 A breakers
- Convenience receptacles with individual breakers:
 - Two 120 VAC, 20 A, GFCI, duplex outlets (NEMA 5-20R)
 - Two 240 VAC, 30 A, twistlock outlets (NEMA L14-30)
 - Two 240 VAC, 50 A, twistlock outlets (Leviton 6369)
- 720 CCA wet cell battery

MAST

- Vertical operation and storage
- Four tubular steel sections with polymer guides
- Winch: Electric, self-braking
- Distinctive angled fixture mount for common light distribution
- 359° rotation – lockable and adjustable from ground with mast fully extended
- Industrial-black powder-coat
- Self-retracting, coiled power cord
- Winch guard

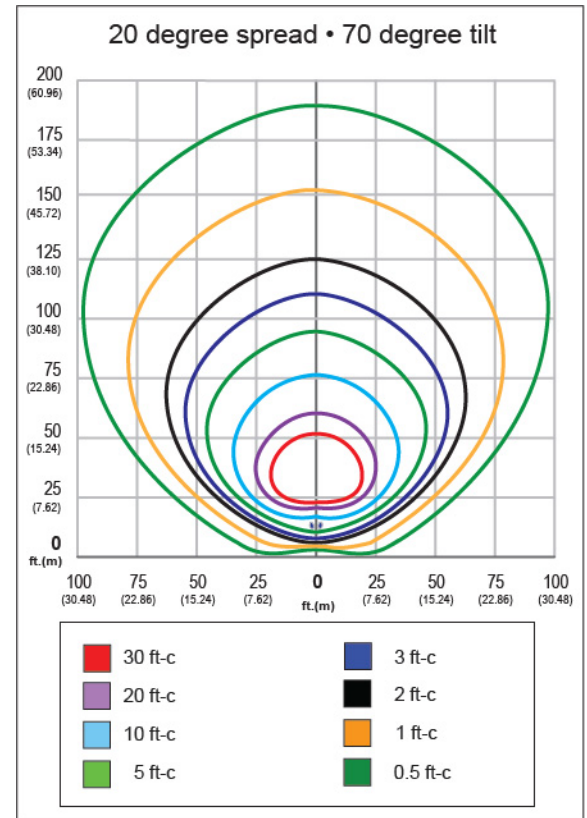

ENCLOSURE

- Heavy-duty, 14-gauge steel
- Stainless steel hinges on doors
- UV & fade resistant, high temperature cured, white polyester powder paint
- Sound rating: 68 dB(A) at 23 ft (7 m) @ prime power
- Lifting point and fork pockets
- Multi-lingual operating and safety decals
- Illuminated license plate holder
- Document holder with owner's manual – includes AC and DC wiring diagrams

TRAILER

- Tubular steel frame
- Removable tongue – 48 in. (1.2 m) length
- 2 in (50 mm) ball hitch
- Four 2,000 lb (907 kg) leveling jacks – lockable in stowed positions
- Side outriggers
- 7,800 lb (3,538 kg) safety chains with spring-loaded safety hooks
- DOT approved lights: Tail, side, brake, and directionals
- 3,000 lb (1,361 kg) leaf spring axle
- Single wall polyethylene fenders
- Tires: P205/75R15
- Front step platform for easy adjustment of light fixtures

OPTIONS*

- Suggested cold-weather options:
 - 60/40 coolant
 - Coolant heater
 - OVR heater blanket
 - Heated fuel filter
 - 720 CCA AGM sealed battery
 - Liquid containment
- Other options:
 - Various trailer hitch types
 - Flat-4 to round-7 trailer adapter
 - Positive air shutdown
 - Ground rod
 - 5 lb. (2.3 kg) fire extinguisher
 - Battery charger – 10 A, 3-stage
 - RPM quick drain
 - Battery disconnect

**Additional options may be available. Please contact a sales representative or the factory for current options.*

DIMENSIONS

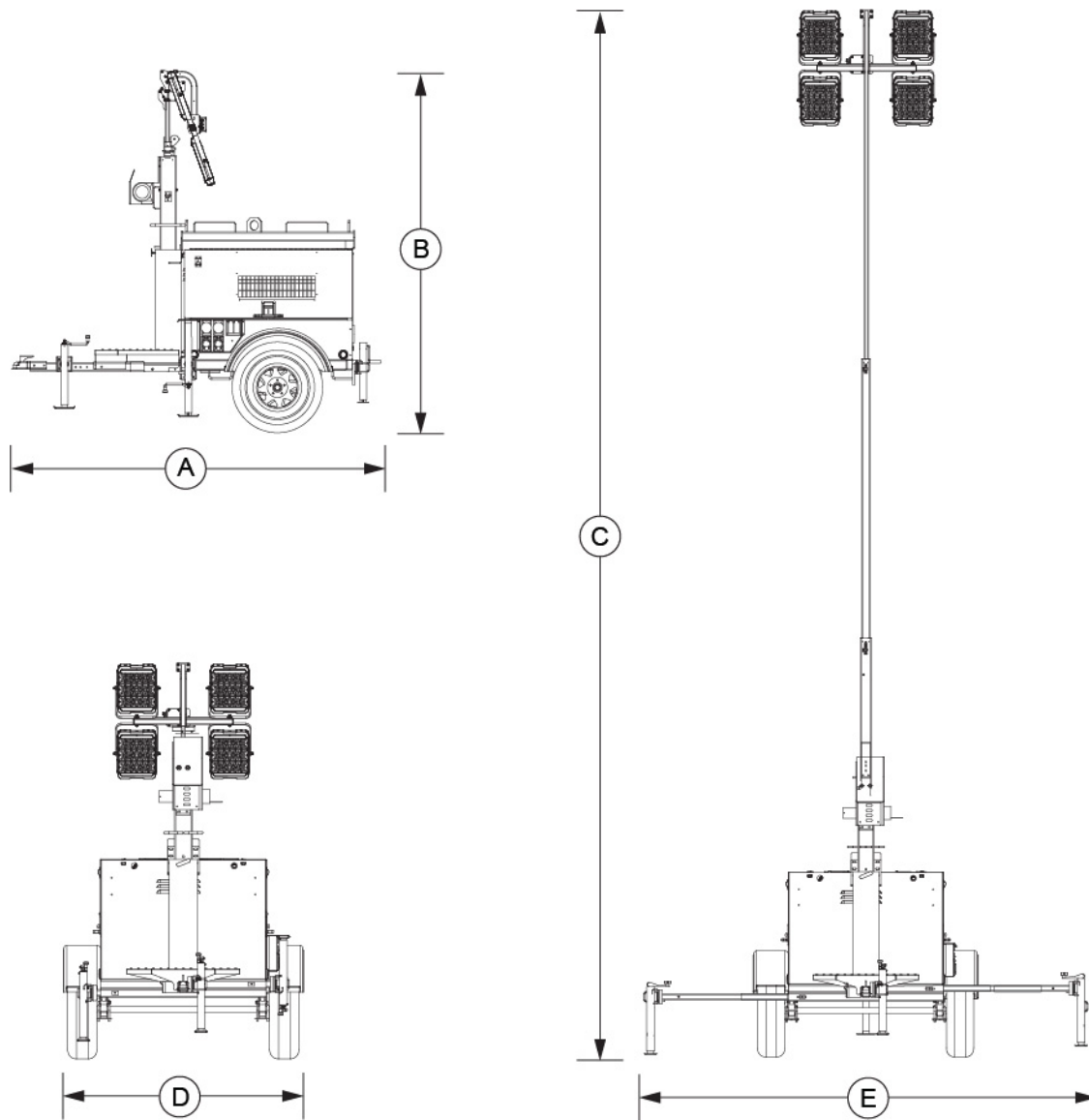

014630

A	B	C	D	E
115 in (2.92 m)	102 in (2.59 m)	23.3 ft (7.11 m)	68 in (1.73 m)	140 in (3.56 m)

WEIGHT

- Dry: 2,184 lb (991 kg)
- Operating: 2,499 lb (1,134 kg)

AMBIENT CLIMATE LIMITATIONS

- Maximum wind speed: 65 mph (105 km/h)
- Ambient temperature range - °F (°C):*
 - Standard unit: 0 (32) to 120 (49)
 - Cold weather unit: -20 (-29) to 120 (49)

Environmental factors such as altitude, humidity, and engine fuel rating can impact temperature tolerance.

WARRANTY

- 2 years/2,000 hours

CERTIFICATIONS

CSA certified

FOR MORE INFORMATION

Owner's manual is available at www.generacmobileproducts.com/service-support/manuals.