

MDG75DF4 | 4.5L | 75 kVA

MOBILE DIESEL GENERATOR SET

EPA Emissions Certification: Final Tier 4

GENERAC® | MAGNUM

Standby Power Rating

68 kW, 85 kVA, 60Hz

Prime Power Rating

60 kW, 75 kVA, 60Hz



Image used for illustration purposes only

Codes and Standards

Generac Magnum products are designed to the following standards:



CSA



NATM



TIER 4 FINAL EMISSIONS



ISO 8528-5

Power When and Where You Need It

Generac Magnum mobile diesel generators are designed and engineered to power a variety of projects, in the most extreme environments. Gensets are configured to meet customer needs, including choice of containment, cold weather packages, trailer options, and more.

Generac Magnum mobile diesel generators are manufactured to deliver reliable power, when and where you need it.

STANDARD FEATURES

ENGINE SYSTEM

- John Deere 4045hfg04_b
- Prime - 97hp, 73kWM @ 1800 rpm
- Standby - 107hp, 80kWH @ 1800 rpm
- 4 cylinder, 4.5 displacement, EPA Final Tier 4

FUEL SYSTEM

- Fuel tank - 165 gallon (625L)
- DEF - 11 gallon (9 usable)
- DEF consumption - 0.26 gph
- 26 hour run time - 6.14 gph consumption

COOLING SYSTEM

- Capable of handling 107°F
- Low coolant shutdown
- Radiator and oil drains plumbed to exterior

SYSTEM OUTPUTS

- 68 kW / 85 kVA – standby-three phase
- 60 kW / 75 kVA – prime-three phase

GENERATOR

- 60 Hz engine/generator
- Marathon Electric
 - Brushless
 - 4-pole
 - Class H insulation
- Voltage regulation ± 1.0% with PM600 Voltage Regulator

ENCLOSURE

- Aluminum, sound attenuated enclosure
 - UV and fade resistant, high temperature cured, white polyester powder paint
 - Insulated and baffled
 - 74 dB(A) at 23 ft (7 m) – prime power
- Fully lockable enclosure including doors and fuel fill and DEF fill
- Emergency stop switch located on outside of enclosure
- Central lifting point
- Multi-lingual operating/safety decals
- Document holder with operating manual including AC/DC wiring diagrams

TRAILER

- DOT approved tail, side, brake, and directional lights; recessed rear lights
- Transportation tie downs
- Safety chains with spring loaded safety hooks
- 3 in (76.2 mm) Lunette ring hitch

WARRANTY

- 2 year limited or 2000 hours
 - Unlimited hours covered in first year

CERTIFICATIONS

- CSA certified

SYSTEM CONTROLS

Power Zone® Controller And Display

- Backlit, 800 x 480 pixel resolution color display
- -40 °F to 185 °F (-40 °C to 85 °C) operating temperature range
- Automatic coarse voltage adjustment
- Integrated fine voltage adjustment
- PLC functionality

Push Buttons For Easy Operation

- Manual or Auto Start
- Engine Start
- Engine Stop/Reset
- Alarm Mute
- Operator Screens
 - Home
 - Engine
 - Generator
 - Voltage Adjust

Scrolling Arrows for Diagnostic Information

- Engine diagnostic display
 - Oil pressure
 - Engine temperature
 - Fuel level
 - Battery
 - After-treatment inlet/outlet temperature
 - Ash/soot levels
- Generator diagnostic display
 - System kW output display
 - Line output and frequency display
- Alarms
 - Warning
 - Shutdown
 - Electrical Trip
 - Engine
- Alarm list – warnings/shutdowns; 250 event history log – date/time stamp
 - Fuel level: warning – 15%; shutdown – 5%
 - Over speed protection: shutdown – 115%
 - Oil pressure: warning – 25 psi; shutdown – 20 psi
 - Coolant temperature: warning – 230 °F (110 °C); shutdown – 235 °F (113 °C)
 - Battery voltage: over – 15VDC; under – 11VDC
 - Generator over voltage: warning – 110%; electrical trip – 125%

- Generator under voltage: warning – 91.4%; shutdown – 70%
- Generator over frequency: warning – 102.5%; electrical trip – 110%
- Generator under frequency: warning – 95%; electrical trip – 90%

- Inputs/Outputs
- Auto Schedule
- Status
- Configuration of controller, firmware, and connections

ELECTRICAL CONTROLS

- Remote start/stop contacts located in receptacle box
- Lockable control box door with diagnostics window
- Lockable lug box with safety switch
 - Trips main breaker when door is opened
 - Disables voltage regulator
- Output ground connection lug inside lug box
- 300A main breaker with shunt trip
- Convenience receptacles with individual breakers (restricted use in high wye mode)
 - Two 120V 20 amp GFCI duplex outlets – (NEMA 5-20R type)
 - Three 125/250V 50 amp, 3-pole, 4-wire Twist-lock (Non-NEMA 6369)
- One 12V / 720 CCA wet cell battery

MDG75DF4 | 4.5L | 75 kVA

MOBILE DIESEL GENERATOR SET

EPA Emissions Certification: Final Tier 4



OPTIONS

ENGINE SYSTEM

- Fuel filter heater
- CCV heater
- 60/40 coolant
- Positive air shutdown
- Cam locks
- 10A battery charger

FUEL SYSTEM

- 110% fluid containment
- Leak detection

TRAILER

- Full size spare tire
- Tool box / storage bin
- 2-5/16" (5.9 cm) ball hitch
- Electric brakes
- Stabilizer jacks
- 2" ball hitch
- Tandem axle

CABINET

- Control panel light
- Interior lights

CONTROL SYSTEM

- 4-position selector switch
- PMG/DVR
- Paralleling
- Buck transformer
- Battery disconnect switch

GENERATOR SYSTEM

- SuperStart



RATING DEFINITIONS

Standby - Applicable for varying emergency load for the duration of a utility power outage.

Prime - Applicable for supplying power to a varying load in lieu of utility for an unlimited amount of running time.

*Consult factory for availability

MDG75DF4 | 4.5L | 75 kVA

MOBILE DIESEL GENERATOR SET

EPA Emissions Certification: Final Tier 4



APPLICATION AND ENGINEERING DATA

ENGINE SPECIFICATIONS

General

Make	John Deere
EPA Emissions Compliance	Final Tier 4
After Treatment System	DOC & SCR
Cylinder #	4
Type	Inline
Displacement	4.5L
Bore – in (mm)	4.2" (106mm)
Stroke – in (mm)	5.0" (127mm)
Compression Ratio	17:1
Intake Air Method	Turbo, air to air, after-cooled

Engine Governing

Governor	Electronic
Frequency Regulation (Steady State)	2%

Lubrication System

Oil Pump Type	Gear
Oil Filter Type	Spin on cartridge
Crankcase Capacity – qts (L)	15.9 (15)

Cooling System

Cooling System Type	Radiator and CAC
Water Pump Type	Engine - belt driven
Fan Type	Pusher
Fan Speed (rpm)	Variable Visc clutch
Fan Diameter – in (mm)	23.2" (590mm)
Cooling System Capacity – qt (L)	22 (20.8)

Fuel System

Fuel Type	ULSD (Ultra low sulfur diesel)
Fuel Specifications	EN590 / ASTM D975
Fuel Filtering (microns)	2 microns (final), 10 micron (primary)
Fuel Inject Pump Make	Denso HP3
Fuel Pump Type	Engine driven - belt
Injector Type	Electronic
Engine Type	Direct Injection
Fuel Supply Line – in (mm)	.313 (8.0)
Fuel Return Line – in (mm)	.313 (8.0)

Engine Electrical System

System Voltage	12VDC
Battery Charger Alternator	STD
Battery Size	720CCA
Battery Voltage	12V (1)
Ground Polarity	Negative

ALTERNATOR SPECIFICATIONS

Standard Model	361CSL1602
Poles	4
Field Type	Rotating
Insulation Class - Rotor	Class H
Insulation Class - Stator	Class H
Total Harmonic Distortion	<3.5%
Telephone Interference Factor (TIF)	<50

Standard Excitation	Brushless
Bearings	Single bearing
Coupling	Direct, flex disc
Prototype Short Circuit Test	Yes
Voltage Regulator Type	Analog
Number of Sensed Phases	1
Regulation Accuracy (Steady State)	+/- 1%

MDG75DF4 | 4.5L | 75 kVA

MOBILE DIESEL GENERATOR SET

EPA Emissions Certification: Final Tier 4



OPERATING DATA

POWER RATINGS

	Standby	Prime
Single-phase, 120/240VAC @ 1.0pf (kW/kVA)	60 / 60	55 / 55
Three-phase, 120/208VAC @ 0.8pf (kW/kVA)	68 / 85	60 / 75
Three-phase, 120/240VAC @ 0.8pf (kW/kVA)	68 / 85	60 / 75
Three-phase, 277/480VAC @ 0.8pf (kW/kVA)	68 / 85	60 / 75

* Circuit breaker limited

STARTING CAPABILITIES (sKVA)

sKVA vs. Voltage Dip

150 kVa

25%

FUEL CONSUMPTION RATES*

Diesel - gal/hr (L/hr)

Percent Load	Standby	Prime
25%	1.74 (6.61)	1.69 (6.37)
50%	2.85 (10.82)	2.69 (10.22)
75%	4.06 (15.38)	3.74 (14.18)
100%	5.33 (20.19)	4.85 (18.39)

Deration – Operational characteristics consider maximum ambient conditions. Derate factors may apply under atypical site conditions.

Please consult a Generac Mobile Products Authorized Service Dealer for additional details. All performance ratings in accordance with ISO3046, BS5514, ISO8528, ISO8665, ISO3046, SAE J1228, SAE J1995, and DIN6271 standards.

MDG75DF4 | 4.5L | 75 kVA

MOBILE DIESEL GENERATOR SET

EPA Emissions Certification: Final Tier 4

GENERAC®

MAGNUM

DIMENSIONS AND WEIGHTS*

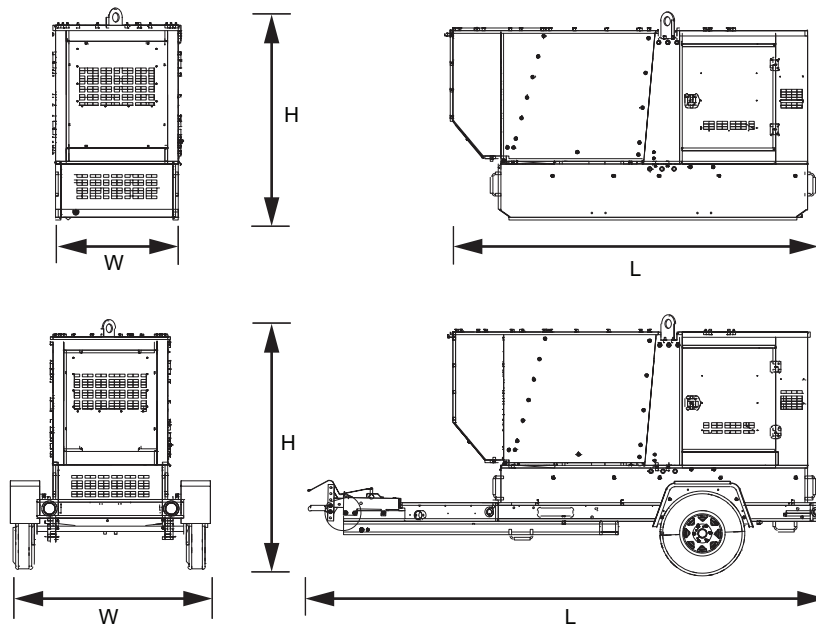

	Run Time Hours	Usable Capacity Gal (L)	L x W x H in (m)	Weight lbs (kg)
Skid	26	146 (551.8)	119 (3.02) x 40 (1.02) x 62 (1.57)	Dry: 3,830 (1,740) Operating: 4,790 (2,170)
Trailer	26	146 (551.8)	170 (4.31) x 69 (1.75) x 80 (2.03)	Dry: 4,530 (2055) 5,490 (2,490)

* All measurements are approximate and for estimation purposes only.

YOUR FACTORY RECOGNIZED GENERAC MOBILE PRODUCTS DEALER

Specification characteristics may change without notice. Dimensions and weights are for preliminary purposes only. Please consult a Generac Mobile Products Authorized Service Dealer for detailed installation drawings.