

ENGINE SYSTEM

- Isuzu® 3CE1-UGZG1
- Diesel fueled
- EPA Final Tier 4
- 3 cylinder
- Naturally aspirated
- 97.6 in³ (1.6 L) displacement
- Power @ 1,800 rpm: 21.1 hp (15.7 kW)
- Air filter: dry type cartridge

Fuel System

- Fuel tank capacity—gal (L):
 - Total: 200 (757.1)
 - Usable: 173 (654.9)
- Fuel consumption rate (engine + burner): 6.25 gph (23.7 Lph)
- Minimum run time: 27.7 hr
- Fuel filter: Spin-on

Cooling System

- Liquid cooled
- Capable of operating at -40 to 100 °F (-40 to 37.8 °C) ambient – not considering derate factors
- Coolant capacity: 2.1 qt (2.0 L)

Lubrication System

- Oil capacity: 7.1 qt (6.7 L)
- Oil filter: Spin-on
- 250-hr service interval**

**Data based on engine manufacturer and field test data after 100-hr engine break-in period. Actual results may vary, according to factors such as age and maintenance of equipment, environmental conditions, and fuel density. For fuel and maintenance recommendations, see owner's manual.*

***For maximum service interval, replace oil filter after 50-hr break-in period. For oil filter model number, see owner's manual.*

HEATER

- Type: Indirect
- Burner: Riello F15 single stage diesel fuel burner
 - Firing rate: 2.55–5.75 gph (9.65–21.77 Lph)
 - Heat produced: 357,000–805,000 BTU/hr (104.6–235.9 kW/hr)
- Temperature range: 120–180 °F (48.9–82.2 °C)
- Air flow: 3,500–5,000 ft³/min (99.1–141.6 m³/min)
- Air ducts: Two 12 in (30.5 cm) diameter
- Efficiency: 85%
- Fan motor: TECO 5 hp (3.73 kW) @ 3,600 rpm
- Fan wheel: BC-SW 135 CL II
- Fan performance:
 - 3,900 ft³/m (110.4 m³/min)
 - 5 in. WG (1.24 kPa) static pressure



Picture shown may not reflect actual configuration.

GENERATOR

- Marathon® 282CSL1504
- 13.5 kW

SAFETY

- Burner fire eye – shuts off fuel pump if no flame is present in burner
- Air differential switch – shuts off burner if no air flow is present

ENCLOSURE

- Material: Steel with powder coat
- Fully lockable – including control box door, service access doors, and fuel fill
- Rear storage for two 12-in×50-ft air ducts
- Operating and safety decals
- Document holder with owner's manual – includes AC and DC wiring diagrams

TRAILER

- 2-5/16 in. ball hitch—adjustable height
- Lift jacks
- Electric brakes
- Transportation tie downs
- Forklift tubes
- DOT approved lights: Tail, brakes, and directionals
- One 6,000 lb (2,721.6 kg) axle
- Tires: 16 in (40.6 cm)

CONTROLS

- LOFA® MC704 micro control panel
- Operating temperature range: -20 to 185 °F (-29 to 85 °C)

BATTERIES

- One 24 V, 720 CCA, wet cell battery

OPTIONS*

- Block heater
- Fire extinguisher
- Hitch
- Spare tire and carrier
- Heated fuel filter
- 60/40 coolant
- Rear stabilizer jacks
- Duct outlet diameter
- 3 in. pintle hitch
- 2 in. BULLDOG® hitch

**Additional options may be available. Contact a sales representative or the factory for current options.*

DIMENSIONS

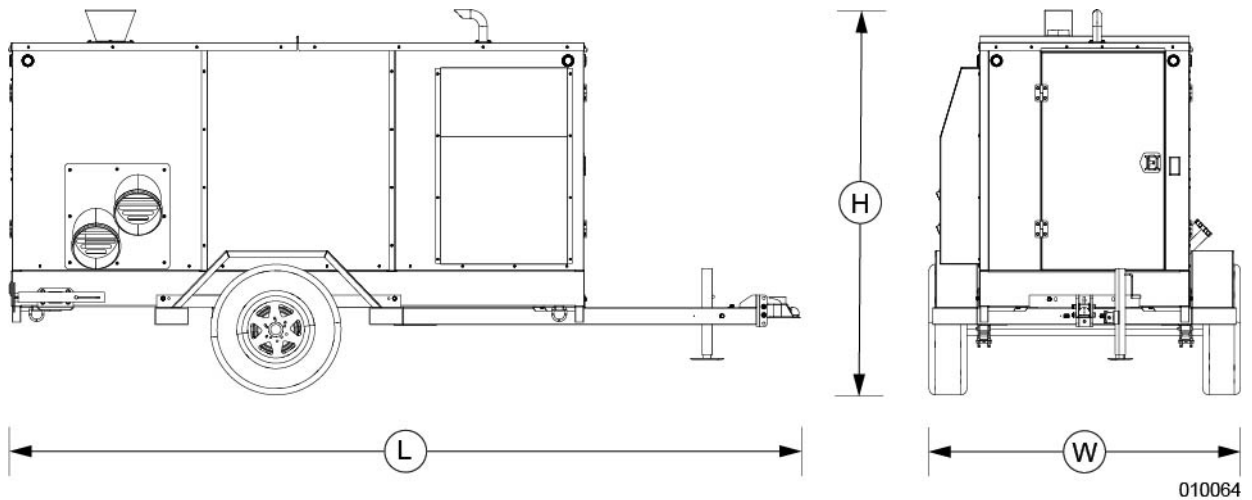

L	W	H
186 in (4.72 m)	91.3 in (2.32 m)	72.0 in (1.83 m)

WEIGHT

- Dry: 4,900 lb (2,223 kg)
- Operating: 6,080 lb (2,758 kg)

WARRANTY

1 year, unlimited hours

CODES AND STANDARDS

Generac Mobile products are designed to the following standards:



TIER 4 FINAL
EMISSIONS



CSA



NATM



TRANSPORT CANADA

FOR MORE INFORMATION

Owner's manual is available at www.generacmobileproducts.com/service-support/manuals.