

ENGINE SYSTEM

- Mitsubishi® L3E
- Diesel fueled
- EPA Tier 4 Final
- 3 cylinder
- 0.95 L displacement
- Power @ 1,800 rpm – HP (kW):
 - Prime: 11.3 (8.4)
 - Standby: 12.2 (9.1)
- Air filter: Dry type cartridge

Fuel System

- Tank usable capacity: 56.4 gal (213.5 L)
- Fuel consumption – gph (Lph):
 - 100% load: 0.59 (2.2)*
- Fill port diameter: 3.5 in (88.9 mm)
- Fuel filter: replaceable element

Cooling System

- Liquid cooled

Lubrication System

- Oil filter: Full flow, spin-on type
- 1,000-hr service interval**

*Data based on engine manufacturer and field test data after 100-hr engine break-in period. Actual results may vary, according to factors such as age and maintenance of equipment, environmental conditions, and fuel density. For fuel and maintenance recommendations, see owner's manual.

**To achieve maximum service interval, replace oil filter after 50-hr break-in period. See owner's manual for oil filter model number.

GENERATOR

- 60 Hz engine/generator
- Marathon Electric® brushless
- Up to 6 kW output
- 120/240 VAC, 50/25 A
- ± 6% capacitor voltage regulation

CONTROLS

- Engraved, aluminum punched and anodized control panel
- Key-activated switch with 4 positions (GLOW PLUG, OFF, RUN, START)
- Independent light switches
- Digital hour meter
- Automatic shutdown for low oil pressure and high coolant temperature



Picture shown may not reflect actual configuration.

FLOODLIGHTS

- Four 1,100 watt metal halide fixtures
 - Lm/bare bulb: 132,000
 - Lm/fixture: 70,356
 - Total bare bulb lm: 528,000
 - Total fixture lm: 281,424
- Efficiency: 120 LPW
- Coverage: @ 0.5 ft-c: 31,902 ft² (2,964 m²)
- Oval aluminum reflector, tempered glass lens
- Silicone gaskets for moisture and dust protection
- Friction disc mounting for tool-free positioning

ELECTRICAL SYSTEM

- 30 A start trip breaker (ensures no-load condition exists at start-up)
- Floodlight circuits with sealed 15 A breakers
- Convenience receptacles with individual breakers:
 - One 120 VAC, 20 A, GFCI, duplex outlets (NEMA 5-20R type)
 - One 240 VAC, 30 A, twistlock outlet (NEMA L6-30R type)
- Ballast Indicator lights
- 440 CCA wet cell battery

MAST

- Vertical operation and storage
- Five tubular steel sections with polymer guides
- Winch: Electric, self-braking
- Distinctive angled fixture mount for common light distribution
- 359° rotation – lockable and adjustable from ground
- Industrial-black powder coat
- Self-retracting, coiled mast cord

ENCLOSURE

- 14-gauge steel
 - UV & fade resistant, high temperature cured, white polyester powder coat
- Sound rating: 68 dB(A) at 23 ft (7 m) @ prime power
- Lifting point and fork pockets
- Multi-lingual operating and safety decals
- Illuminated license plate holder
- Document holder with owner's manual – includes AC and DC wiring diagrams

TRAILER

- Tubular steel frame
- Front step platform for easy adjustment of light fixtures
- 2 in (50.8 mm) ball hitch
- Four 2,000 lb (907.18 kg) leveling jacks – lockable into stowed positions
- Side outriggers
- 7,800 lb (3,538 kg) safety chains with spring-loaded safety hooks
- Removable tongue – 48 in (121.9 cm) long
- DOT approved lights: Tail, side, brake, and directionals
- 2,200 lb (997.9 kg) leaf spring axle
- Tires: ST175/80D13 – 6 ply

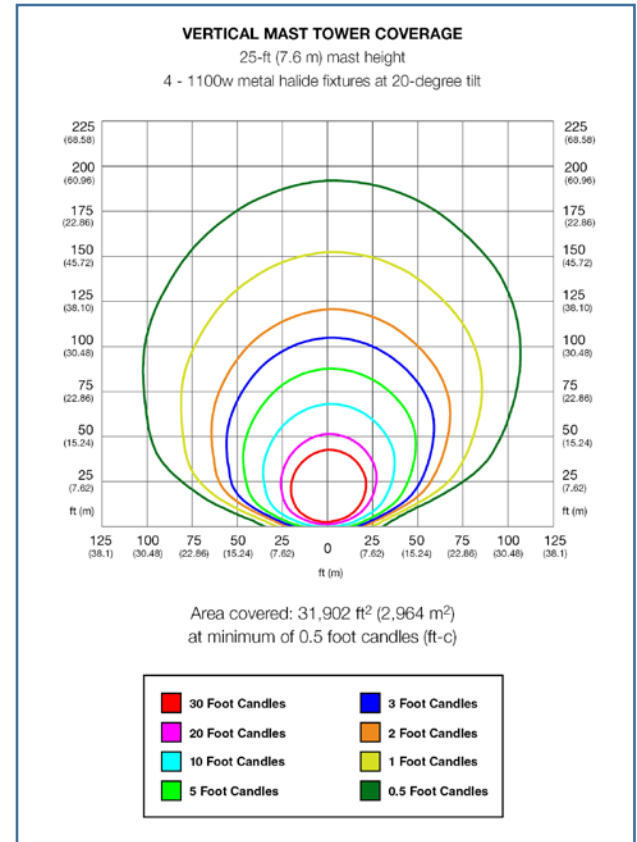

OPTIONS*

- Power Zone® controller
- Cold weather package
- Canadian package – includes the following:
 - 60/40 coolant
 - Heated radiator hose
 - Heated fuel filter
 - 775 CCA AGM sealed battery
 - Liquid containment

*Additional options may be available. Contact a sales representative or the factory for current options.

DIMENSIONS

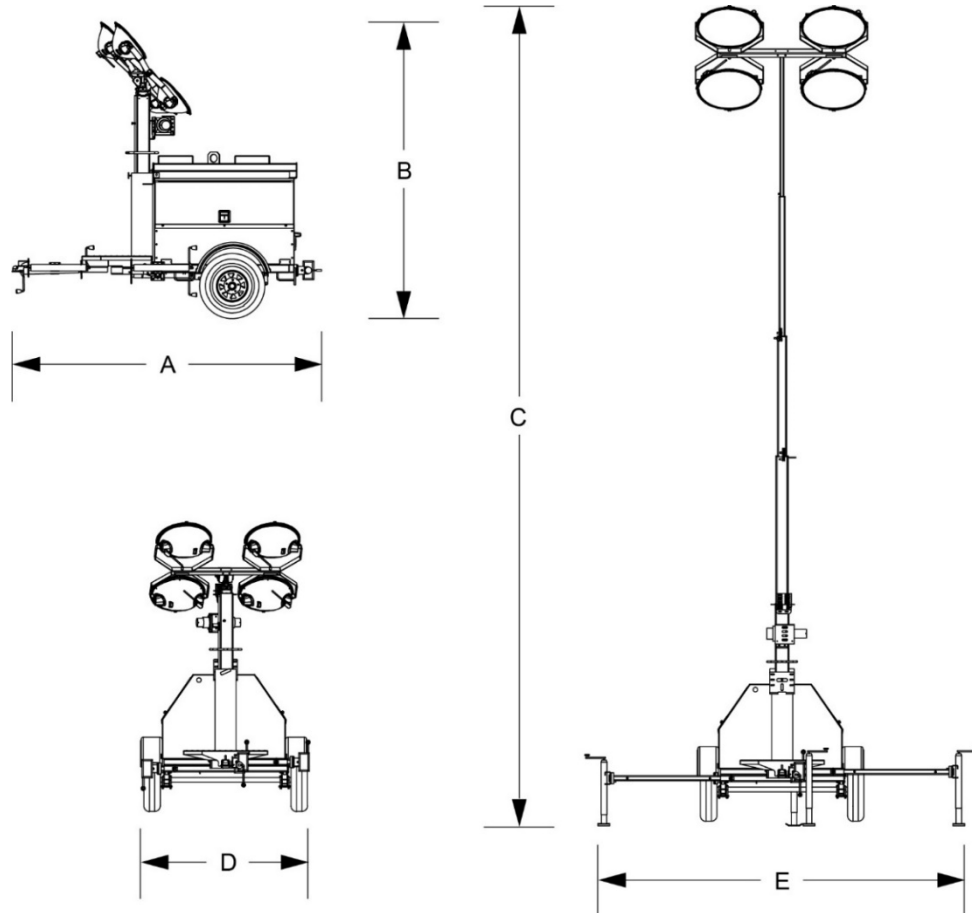

A	B	C	D	E
115 in (2.92 m)	107 in (2.71 m)	25 ft (7.6 m)	68 in (1.73 m)	140 in (3.56 m)

WEIGHT

- Dry: 1,759 lb (798 kg)
- Operating: 2,162 lb (981 kg)

AMBIENT CLIMATE RATINGS

- Wind rating: 65 mph (105 kph)
- Maximum air temperature: 120 °F (49 °C)

WARRANTY

1 year, unlimited hours/2 years, 2,000 hours

CERTIFICATIONS

CSA Certified

FOR MORE INFORMATION

Owner's manual is available at www.generacmobileproducts.com/service-support/manuals.