

ENGINE SYSTEM

- Kubota® D1005
- Diesel fueled
- EPA Tier 4
- 3 cylinder
- 1.0 L displacement
- Liquid cooled
- Power @ 1,800 rpm – HP (kW):
 - Prime: 11.7 (8.72)
 - Standby: 13.1 (9.77)

Fuel System

- Polyethylene tank – 39.9 gal (151.04 L) usable fuel volume
- Fuel consumption – gal/hr (L/hr):
 - 100% load: 0.67 (2.54)*
- Exterior fill port diameter: 3.5 in (88.9 mm)

Cooling System

- Air filter: Dry type cartridge
- Capable of operating at 120°F (49°C) ambient

Lubrication System

- Oil filter: Full flow, spin-on type
- 1,000-hr service interval**

**Results based on engine manufacturer and field test data after 100-hour engine break-in period and may vary based on factors including age and maintenance of equipment, environmental conditions and fuel density. Consult the Owner's Manual for fuel and maintenance recommendations.*

***To achieve maximum service interval, replacement of oil filter after 50-hour break-in period is required. Consult Owner's Manual for required oil filter model number.*

GENERATOR

- 60 Hz engine/generator
- Marathon Electric® brushless
- Up to 6 kW output
- 120/240 VAC, 50/25 A
- ± 6% capacitor voltage regulation

CONTROLS

- External, illuminated control panel with sealed switches
- 4-position key activated switch (off, run, glow, start)
- Digital hour meter
- Automatic low oil pressure/high temperature shutdown system



FLOODLIGHTS

- Four [4] 1,100 watt metal halide
 - Lm/bare bulb: 132,000
 - Lm/fixture: 70,356
 - Total bare bulb lm: 528,000
 - Total fixture lm: 281,424
- Efficiency: 120 LPW
- Coverage: @ 0.5 ft-c: 39,241 ft² (3,646 m²)
- Oval aluminum reflector
- Tempered glass lens
- Silicone gaskets for moisture and dust protection
- Friction disc mounting for tool less positioning
- Individual floodlight On/Off switches

ELECTRICAL SYSTEM

- 30 A start trip breaker (ensures no-load condition at start-up)
- Floodlight circuits with sealed 15A breakers
- Convenience receptacles with individual breakers:
 - (1) 120 VAC 20 Amp GFCI duplex outlets (NEMA 5-20R type)
 - (1) 240 VAC, 30 A, twistlock outlet (NEMA L6-30R type)
- 440CCA CCA wet cell battery
- Wiring sized and fused to amperage draw required

MAST

- Wind Rating: 65 mph (105 kph)
- Vertical mast; 23 ft. (7 m), 5-section with ground adjustable light fixtures
- Dual handle manual winch for ease of deployment: electric winch optional
- Distinctive angle fixture mount for common light distribution
- 359° ground rotational mast with mast fully extended
- Industrial black powder coat finish with polymer guides

ENCLOSURE

- Injection-molded hood enclosure with UV protected colorant
- 68 dB(A) at 23 ft. (7 m) – prime power
- Flip hood engine compartment for ease of service
- Multi-lingual operating/safety decals
- License plate holder with light
- Manual holder with operating manual

TRAILER

- Tubular steel frame
- (3) 1200 lb. (544 kg) tube and sleeve leveling jacks
- All jacks transport and lock in position for storage
- Side outriggers deployed – 10 in. (25.4 cm) span
- 7,800 lb. (3538 kg) safety chains with spring loaded safety hooks
- 2 in. (50.8 mm) ball hitch
- Molded polyethylene fenders
- DOT-approved LED tail, side, brake, and directional lights

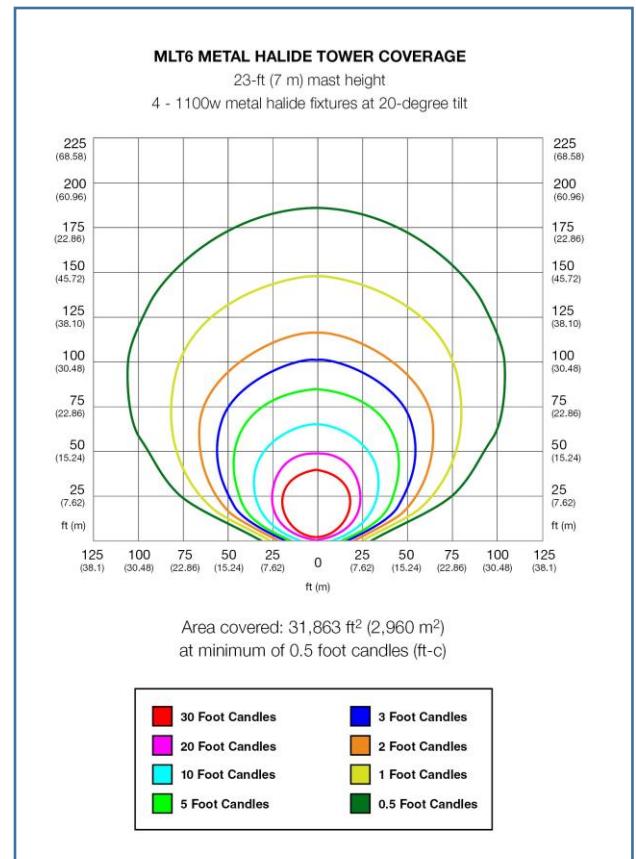

- 2200 lb. (907 kg) leaf spring axle
- ST175/80D13 – 6 ply
- 47 in. (119.4 cm) track width

DIMENSIONS

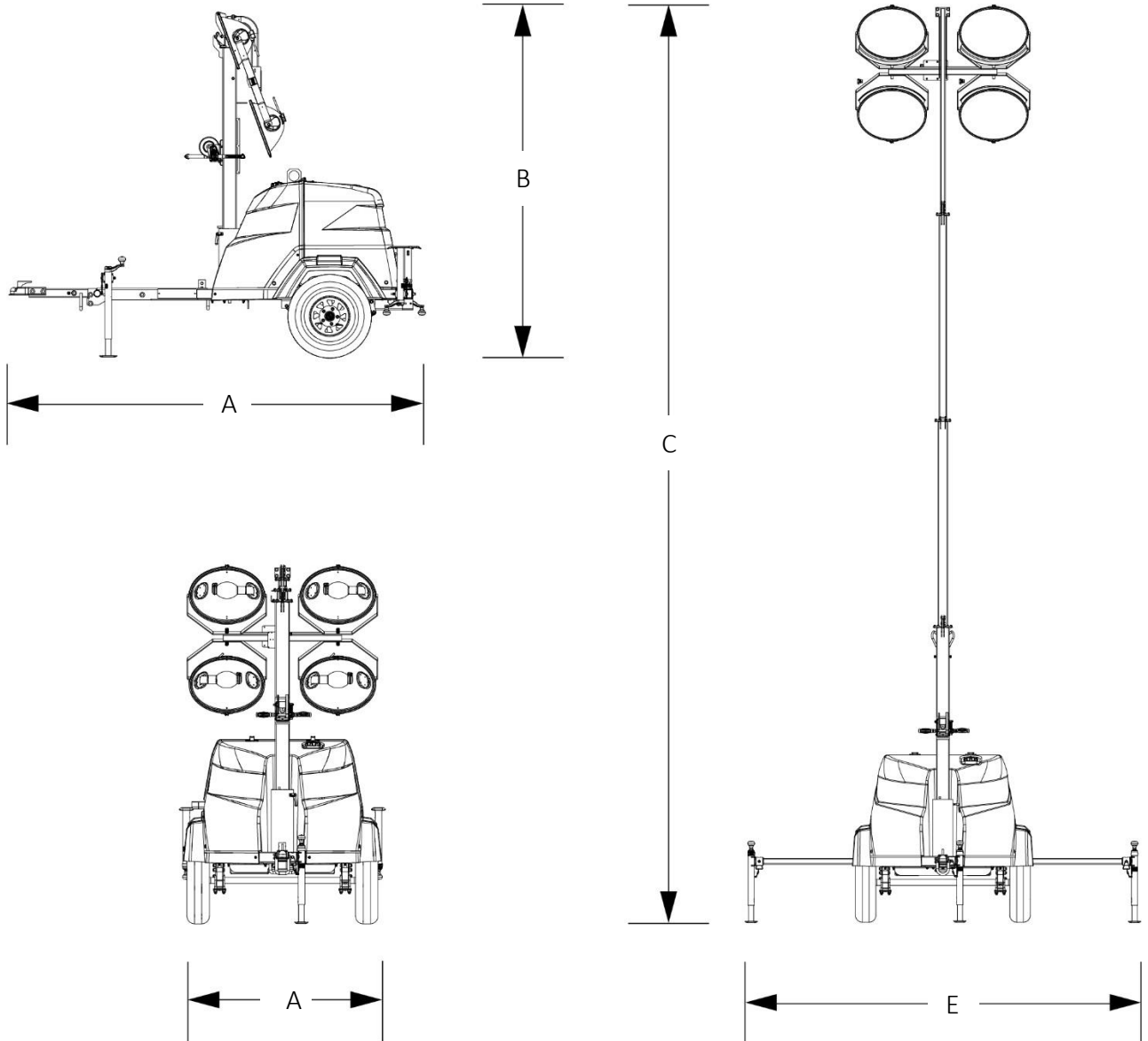

A	B	C	D	E
118 in (3 m)	101 in (2.6 m)	23 ft (7 m)	57 in (1.5 m)	120.5 in (3.1 m)

WEIGHT

- Dry weight: 2104 lbs. (954 kg)
- Operating weight: 2317 lbs. (1051 kg)

OPTIONS

- Digital Power Zone Controller
- Electric Winch
- Cold weather package options
- Canadian Package (CAN)
 - 60/40 coolant
 - Radiator hose heater
 - Heated fuel filter
 - 775CCA AGM sealed battery
 - Liquid containment
- Additional options available. Please contact a sales representative or the factory for current options

WARRANTY

- 1 Year / Unlimited Hours
- 2 Years / 2000 Hours

CERTIFICATIONS

CSA Certified

FOR MORE INFORMATION

Owner's manual is available at www.generacmobileproducts.com/resources-tools/manuals.