

ENGINE SYSTEM

- Isuzu® 4JJ1T
- Diesel fueled
- EPA Final Tier 4
- 4 cylinder
- Series turbocharged
- 3.0 L displacement
- Power @ 2,000 rpm: 73 hp (54 kW)
- Air filter: Dry type cartridge

Fuel System

- Fuel tank capacity—gal (L):
 - Total: 173 (654.9)
 - Usable: 160 (605)
- Fuel consumption rate: 3.55 gph (13.44 Lph)
- Minimum run time: 45 hr
- Fuel filter: Spin-on

Cooling System

- Liquid cooled
- Capable of operating at -40 to 100 °F (-40 to 37.8 °C) ambient
- Coolant capacity: 6.3 qt (6.0 L)

Lubrication System

- Oil filter: Spin-on
- 500-hr service interval**

**Data based on engine manufacturer and field test data after 100-hr engine break-in period. Actual results may vary, according to factors such as age and maintenance of equipment, environmental conditions, and fuel density. For fuel and maintenance recommendations, see owner's manual.*

***For maximum service interval, replace oil filter after 50-hr break-in period. For oil filter model number, see owner's manual.*

HEATER

- Type: Flameless, self-contained
- Heat produced: Up to 485,000 BTU/hr (142.1 kW/hr)
- Temperature range: 120–180 °F (48.9–82.2 °C)
- Air flow: 2,650–5,500 ft³/min (807.7–1,676.4 m³/min)
- Air ducts: Two 12 in (30.5 cm) diameter
- Efficiency: Up to 92%
- Heat transfer fluid (HTF):
 - Pump: Variable displacement piston pump
 - Tank capacity: 14 gal (53 L)
 - System capacity: 25 gal (95 L)
 - Hydraulic oil type: Mobile DTE10 ISO VG68



Picture shown may not reflect actual configuration.

HYDRAULIC LOOP

- Pump: Metaris 63 cc variable displacement piston pump
- Two hydraulic oil filters – 9 and 20 microns

SAFETY

- Positive air shutdown
- Self-contained
- Automatic shutdown for high hydraulic oil temperature, high hydraulic oil pressure, engine overspeed, low engine oil, low fuel, and low hydraulic oil
- 110% containment

ENCLOSURE

- Material: Steel with powder coat
- Fully lockable – including control box door, service access doors, and fuel fill
- Rear storage for two 12-in×50-ft air ducts
- Operating and safety decals
- Document holder with owner’s manual – includes wiring diagrams

TRAILER

- 2-5/16 in ball hitch—adjustable height
- Lift jacks
- Electric brakes
- Transportation tie downs
- Forklift tubes
- DOT approved lights: Tail, brakes, and directionals
- One 6,000 lb (2,721.6 kg) axle
- Tires: 16 in (40.6 cm)

CONTROLS

- Murphy controller
- TFT color graphic LCD display with LED backlight
- Operating temperature range: -22 to 149 °F (-30 to 65 °C)

BATTERIES

- Two 12 V, 950 CCA, wet cell batteries

OPTIONS*

- Block heater
- Fire extinguisher
- Hitch
- Spare tire and carrier
- Heated fuel filter
- 60/40 coolant
- Rear stabilizer jacks

**Additional options may be available. Contact a sales representative or the factory for current options.*

DIMENSIONS

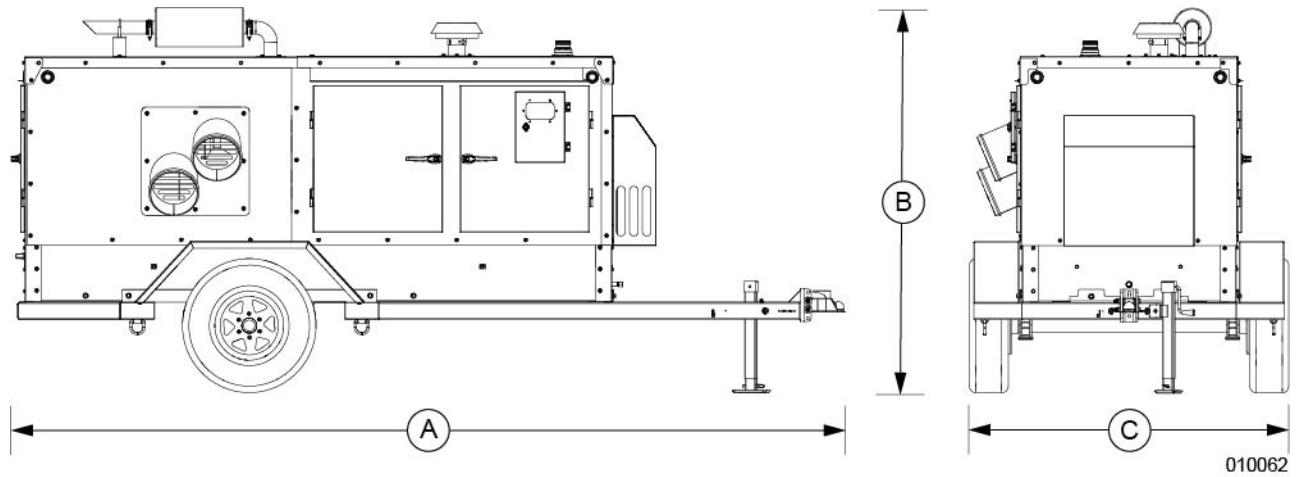

A	B	C
191 in (4.85 m)	72 in (1.83 m)	88 in (2.24 m)

WEIGHT

- Dry: 5,540 lb (2,513 kg)
- Operating: 6,400 lb (2,903 kg)

WARRANTY

1 year, unlimited hours

CODES AND STANDARDS

Generac Mobile products are designed to the following standards:



TIER 4 FINAL
EMISSIONS



CSA



NATM



TRANSPORT CANADA

FOR MORE INFORMATION

Owner's manual is available at www.generacmobileproducts.com/service-support/manuals.