

### ENGINE SYSTEM

- Isuzu® 3CE1-UGZG1
- Diesel fueled
- EPA Final Tier 4
- 3 cylinder
- Direct injection
- Naturally aspirated
- 97.6 in<sup>3</sup> (1.6 L) displacement
- Power @ 1,800 rpm: 21.1 hp (15.7 kW)
- Air filter: dry type cartridge

### Fuel System

- Fuel tank capacity—gal (L):
  - Total: 269 (1,020)
  - Usable: 265 (1,004)
- Fuel consumption rate (engine +burner): 8.5 gph (32.2 Lph)
- Maximum run time: 31.2 hr
- Fuel filter: Spin-on

### Cooling System

- Water cooled, utilizing organic acid technology (OAT)
- Capable of operating at -40 to 100 °F (-40 to 37.8 °C) ambient – not considering derate factors
- Coolant capacity: 2.1 qt (2.0 L)

### Lubrication System

- Oil capacity: 7.1 qt (6.7 L)
- Oil filter: Spin-on
- 250-hr service interval\*\*

*\*Data based on engine manufacturer and field test data after 100-hr engine break-in period. Actual results may vary, according to factors such as age and maintenance of equipment, environmental conditions, and fuel density. For fuel and maintenance recommendations, see owner's manual.*

*\*\*For maximum service interval, replace oil filter after 50-hr break-in period. For oil filter model number, see parts manual.*

### HEATER

- Type: Indirect
- Burner: Riello R38/2 diesel fuel burner
  - High fire: 896 to 1,708 MBTU/hr, 6.4 to 12.2 gph (24.23 to 46.18 Lph)
  - Low fire: 448 to 869 MBTU/hr, 3.2 to 6.4 gph (12.11 to 24.23 Lph)
- Heat produced: Up to 1,200,000 BTU/hr (352 kW/hr)
- Temperature range: 120–180 °F (48.9–82.2 °C)
- Air flow: 6,500 ft<sup>3</sup>/min (184.06 m<sup>3</sup>/min)
- Air ducts: One 20 in (50.8 cm) diameter
- Efficiency: 85%
- Fan motor: TECO 7.5 hp @ 1,800 rpm
- Fan wheel: BC-SW 222 CL II
- Fan output: 6,500 cfm @ 5.5 in. WC static pressure



Picture shown may not reflect actual configuration.

### GENERATOR

- Marathon® 282CSL1504
- 13.5 kW

### ENCLOSURE

- Material: Steel with powder coat
- Fully lockable
- Storage for two 20-in × 50-ft air ducts
- Multi-lingual operating and safety decals
- Document holder with owner's manual – includes AC and DC wiring diagrams

### TRAILER

- 2-5/16 in. ball hitch—adjustable height
- Lift jacks
- Electric brakes
- Transportation tie downs
- Forklift tubes
- DOT approved lights: Tail, brakes, and directionals
- Two 6,000 lb (2,721.6 kg) axles
- Tires: 16 in (40.6 cm)

### CONTROLS

- LOFA™ MC704 controller
- Operating temperature range: -20 to 185 °F (-29 to 85 °C)

### BATTERIES

- One 12 V, 720 CCA, wet cell battery

### OPTIONS\*

- Rear stabilizer jacks
- Duct outlet diameter
- 2-5/16 in. BULLDOG® hitch – adjustable height
- 3 in. ring – adjustable height

*\*Additional options may be available. Contact a sales representative or the factory for current options.*

## DIMENSIONS

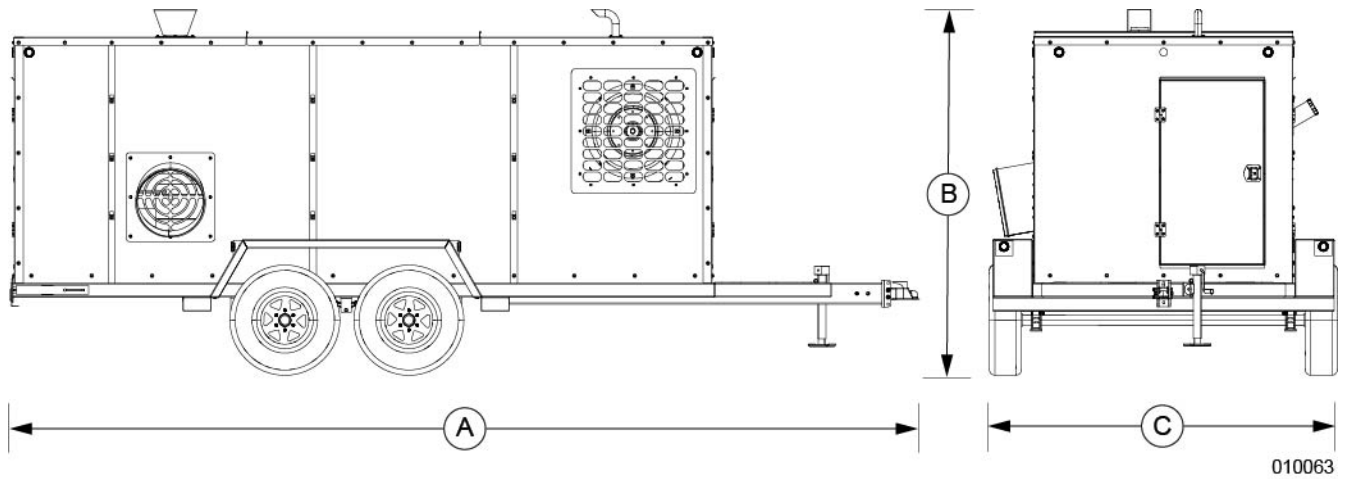

A	B	C
254 in (4.72 m)	103 in (2.62 m)	96 in (2.44 m)

## WEIGHT

- Dry: 8,265 lb (3,749 kg)
- Operating: 10,280 lb (4,663 kg)

## WARRANTY

1 year, unlimited hours

## CODES AND STANDARDS

Generac Mobile products are designed to the following standards:



TIER 4 FINAL  
EMISSIONS



NATM



TRANSPORT CANADA

## FOR MORE INFORMATION

Owner's manual is available at [www.generacmobileproducts.com/service-support/manuals](http://www.generacmobileproducts.com/service-support/manuals).