

### Subject

OVR heater installation in mobile diesel generators MMG25IF4 and MMG45IF4.

### Models Affected

MMG25IF4, MMG45IF4

### Table of Contents

	Page
Introduction .....	1
Recommended Tools .....	1
SKA0036 & SKA0037 Kit Components .....	2
Installing OVR Heater .....	3

### Introduction

The following instructions illustrate OVR heater installation in mobile diesel generators MMG25IF4 and MMG45IF4.

**Note:** Before beginning the following procedure, verify relevant kit components listed on page 2 are present. If items are missing, contact Generac Mobile Products LLC at 1-800-926-9768.

#### **▲ WARNING**

**Consult Manual. Read and understand manual completely before using product. Failure to completely understand manual and product could result in death or serious injury. (000100a)**

#### **▲ WARNING**

**Accidental Start-up. Disconnect the negative battery cable, then the positive battery cable when working on unit. Failure to do so could result in death or serious injury. (000130)**

#### **▲ WARNING**

**California Proposition 65. Engine exhaust and some of its constituents are known to the state of California to cause cancer, birth defects, and other reproductive harm. (000004)**

#### **▲ WARNING**

**California Proposition 65. This product contains or emits chemicals known to the state of California to cause cancer, birth defects, and other reproductive harm. (000005)**

### Recommended Tools

- 3/4 in. wrench
- 11/16 in. wrench
- Pliers
- Heat gun
- Thread-seal tape

## SKA0036 & SKA0037 Kit Components

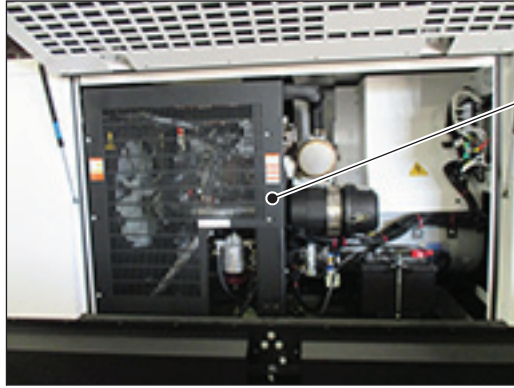

**Figure 1 - Kit Components**

Item	Part Number	Qty	Description	Notes
	MMG25IF4 MMG45IF4			
1	36258B	1	Bracket, engine heater element	
2	68863B 68720B	1	Weldment, pipe intake	
3	68682	1	Harness, PCV hose heater	Includes end-cap
4	68374	1	Harness, heat cable fuse and thermal switch	
5	19400	8	Cable tie - 8.0 x .185 in.	
6	68526	1	Foam, Isuzu T4 engine heater bracket	
7	38467	1	Cord grip, 1/2 liquid tight for heat cable	
8	14219	1	Strain relief, .75 in. w/nut	
9	60502	1	Fitting, straight -.500 x .625 in.	
10	68864	1	Fuse assembly, 10A 250V	
11	66685		Mount, cable tie	

## Installing OVR Heater

1. Verify unit is OFF.
2. Disconnect negative battery cable and secure away from terminal.
3. See *Figure 2*. Remove left guard.



**Figure 2 - Left Guard**

4. See *Figure 3*. Remove pipe intake weldment assembly, as follows.

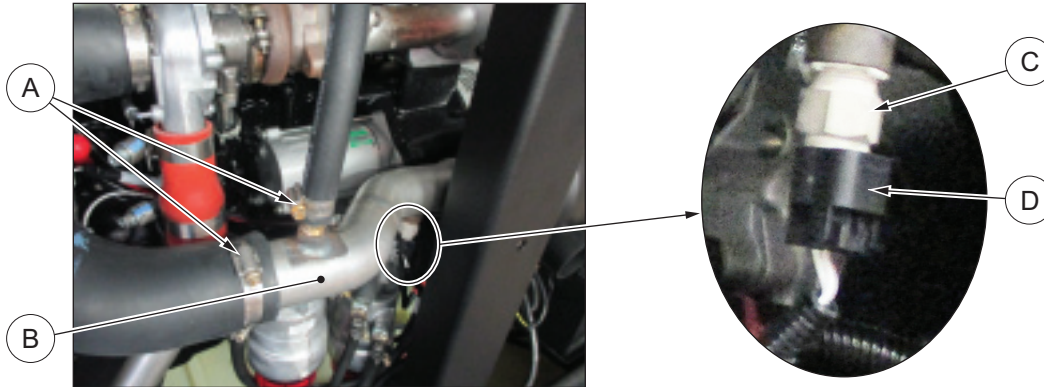

**Figure 3 - Clamps and Harness**

Item	Description
A	Clamps
B	Pipe intake weldment assembly (weldment)
C	Plastic fitting
D	Harness

- a. Loosen clamps securing hoses to weldment.
- b. Disconnect harness from plastic fitting.

- c. See *Figure 4*. Detach hoses from weldment. Retain hose clamps. Remove weldment from unit.



**Figure 4 - Detaching Hoses, Removing Weldment**

5. See *Figure 5*. Remove PCV hose from PCV valve. Retain hose and clamp.

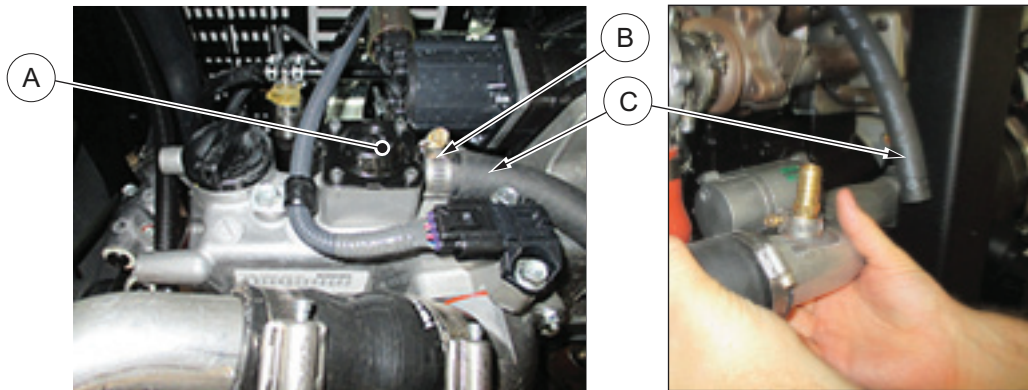

**Figure 5 - PCV Hose to PCV Valve**

Item	Description
A	PCV valve
B	Clamp
C	PCV hose

6. See *Figure 6*. Remove plastic and brass fittings from weldment. Retain plastic fitting. Discard brass fitting. Discard weldment.

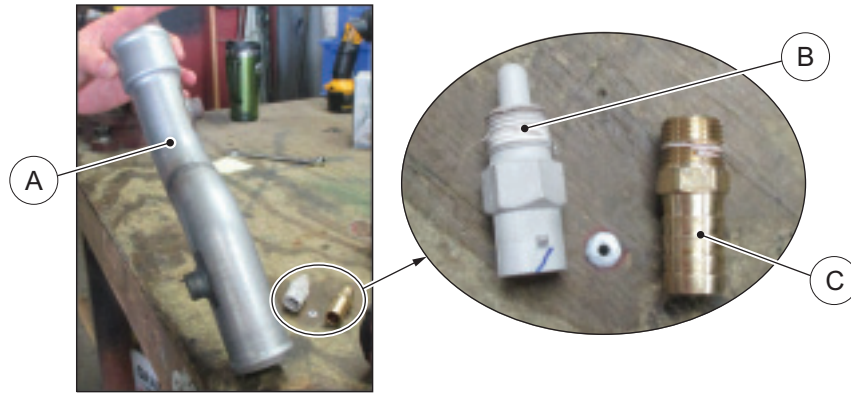

**Figure 6 - Weldment, Fittings Removed**

Item	Description
A	Weldment
B	Plastic fitting
C	Brass fitting

**Note:** If used thread-seal tape remains on threads of plastic fitting, remove it.

7. Wrap thread-seal tape around threads of the following fittings.
  - Plastic fitting (retained in step 6)
  - **New** brass fitting (PN 60502)
8. Obtain **new** weldment (PN below).

Model	Weldment PN
MMG25IF4	68863B
MMG45IF4	68720B

9. See *Figure 7*. Install fittings from step 7 to specified openings in weldment. Tighten fittings securely.



**Figure 7 - Fitting and Cord Grip Locations**

Item	Description
A	Plastic fitting opening
B	Cord grip opening
C	Brass fitting opening

**Note:** Fittings must be threaded in specified openings.



10. See *Figure 8*. Prepare **new** cord grip (PN 38467), as follows.

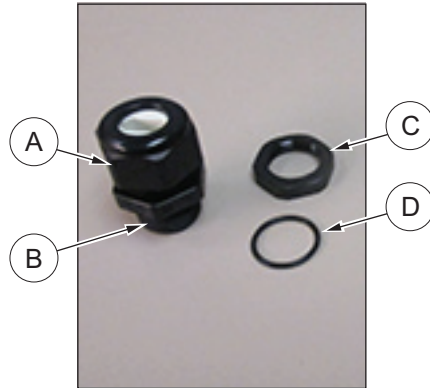

**Figure 8 - Cord Grip**

Item	Description
A	Cap
B	Threads
C	Ring
D	Gasket

- a. Remove and discard ring and gasket.
  - b. Wrap thread-seal tape around threads.
  - c. See *Figure 7*. Attach to specified opening in weldment.
  - d. Loosen, but do not remove, cord grip cap.
11. Obtain PCV hose heater harness (PN 68682).
12. See *Figure 9*. Slide heat cable (yellow) through cord grip, then through weldment, and then through brass fitting; as shown.

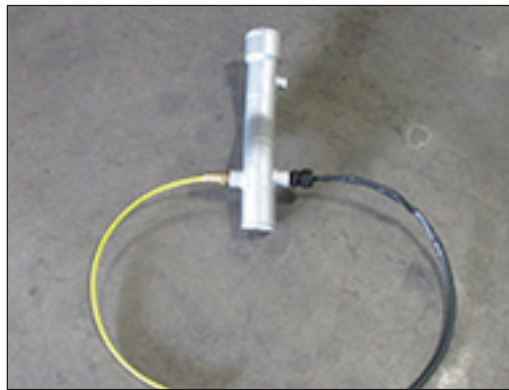

**Figure 9 - Heat Cable Through Weldment and Fittings**

13. See *Figure 10*. Rotate heat cable, as shown.



Correct



Incorrect

**Figure 10 - Heat Cable Position Inside Weldment**

14. See *Figure 11*. Install end-cap onto heat cable, as shown. Use heat gun to shrink cap to cable.

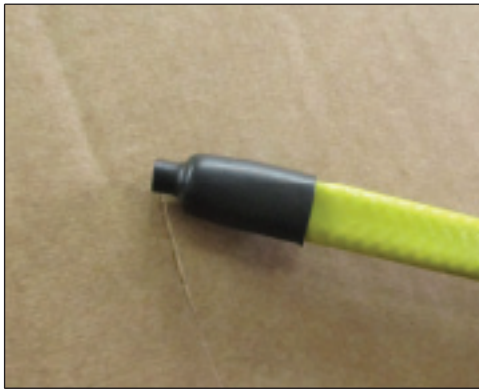

**Figure 11 - Shrink End-Cap to Cable**

15. See *Figure 12*. Slide PCV hose (removed in step 5) on heat cable and brass fitting. Secure to brass fitting with clamp removed in step 4a.

16. Adjust heat cable until half the end-cap protrudes from end of hose, as shown.



**Figure 12 - Heat Cable Through PCV Hose—No Yellow Visible**

**IMPORTANT NOTE:** *If yellow protrudes from end of hose, the assembly will not fit.*

17. Tighten cord grip cap (loosened in step 10d).

**IMPORTANT NOTE:** *See Figure 10. Hold cable in correct position with pliers while tightening cord grip cap.*

18. Attach weldment to unit, as follows.

- a. See [Figure 5](#). Attach hose with heat cable to PCV valve. Secure with clamp retained in step 5.
- b. See [Figure 13](#). Attach remaining hose and clamp (removed in step 4) to weldment.

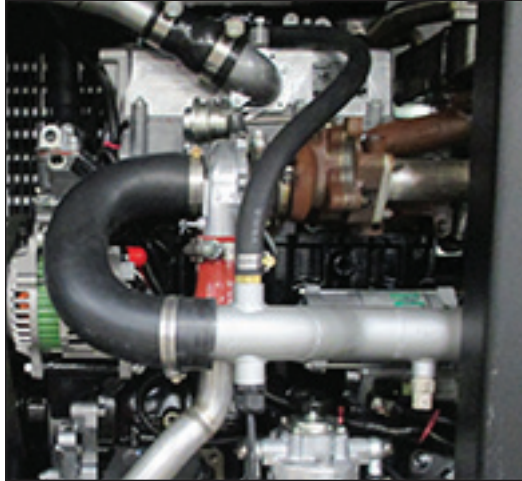

**Figure 13 - Weldment, Installed**

- c. Connect harness (removed in step 4) to plastic fitting in weldment.



19. Route heater harness to control box, as follows.

- a. See *Figure 14*. Route harness behind fuel filters and under air filter, as shown. Just in front of air filter housing clamp, route toward generator.

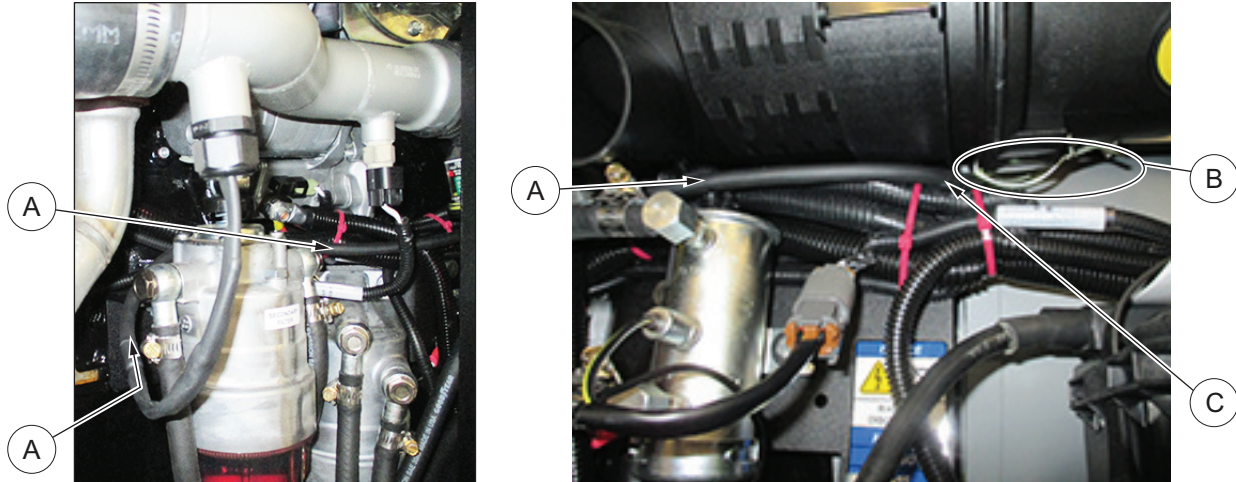

**Figure 14 - Harness Routing**

Item	Description
A	Heater harness
B	Air filter housing clamp
C	Change of direction, toward generator

- b. Route harness over generator, as shown.



**Figure 15 - Harness Routed Over Generator**

20. See *Figure 16*. Secure heater harness with cable-ties, as shown.



**Figure 16 - Cable Ties**

21. See *Figure 17*. Remove backing from foam (PN 68526) and affix foam to bracket (PN 36258B), as shown.



**Figure 17 - Affix Foam to Bracket**

22. See *Figure 18*. Install bracket to unit, as follows.

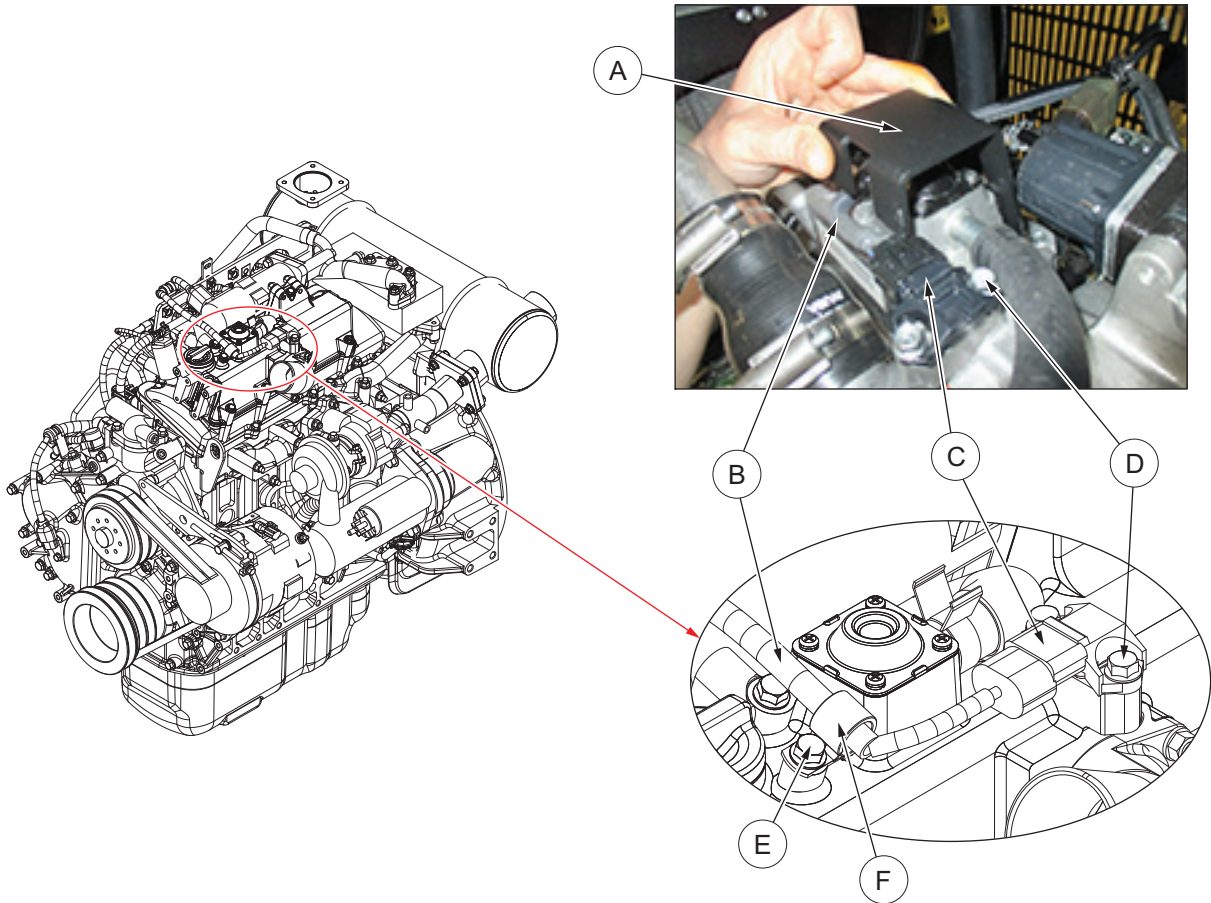

**Figure 18 - Parts Must be Moved to Accommodate Bracket**

Item	Description
A	Bracket installation location
B	Sensor cable
C	Sensor housing
D	Sensor housing screw
E	Sensor cable P-clip screw
F	P-clip

- a. Remove and retain sensor cable P-clip screw. Discard P-clip.
- b. Remove and retain sensor housing screws.

c. See *Figure 19*.

- i. Install sensor housing and sensor cable, as shown. Secure with hardware removed in step b.
- ii. Install bracket, as shown. Secure with hardware removed in step a.

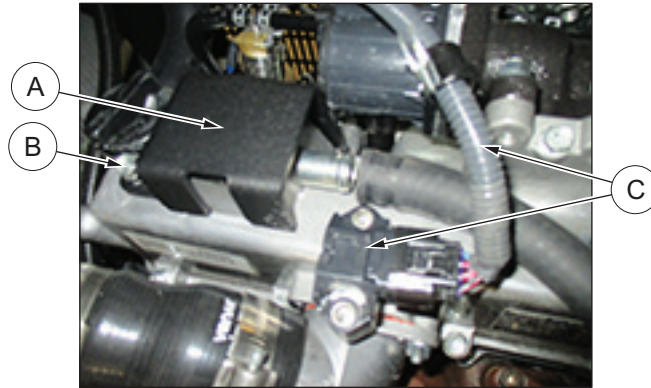
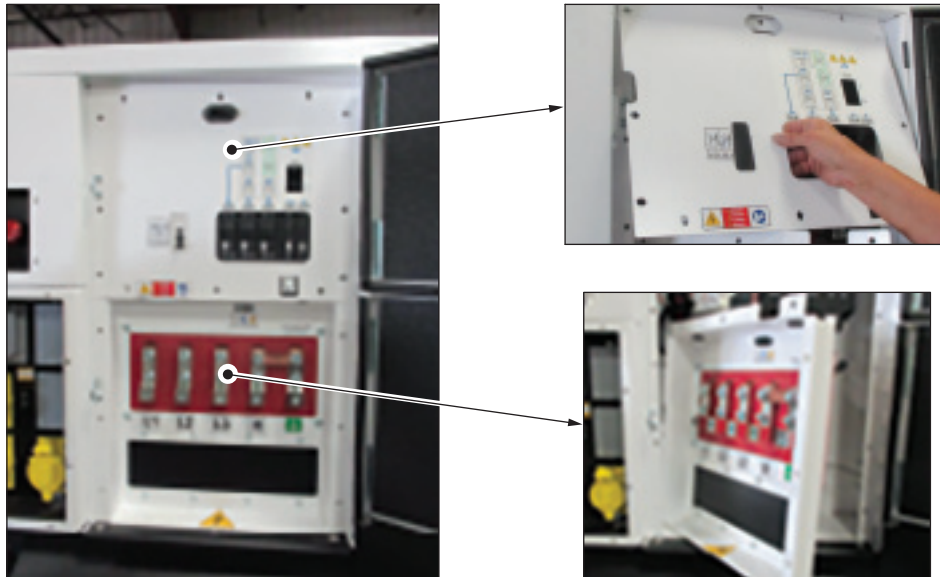

**Figure 19 - Correct Position of Sensor Housing, Cable, and Bracket**

Item	Description
A	Bracket, installed
B	Hardware removed in step a
C	<b>New</b> positions of sensor housing and cable

23. Connect power supply, as follows.

- a. Remove control box panels. Retain for later use.



**Figure 20 - Control Box Panel Removal**



- b. See [Figure 21](#). Drill a 7/8 in. hole in control box, in location shown. Install strain relief (PN 14219) in hole and route heater harness through strain relief, as shown.

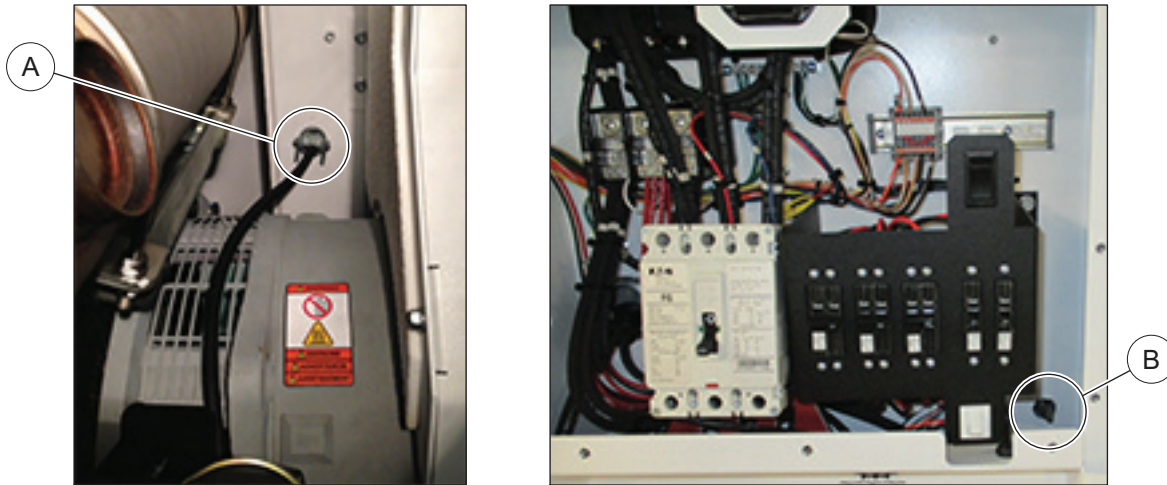
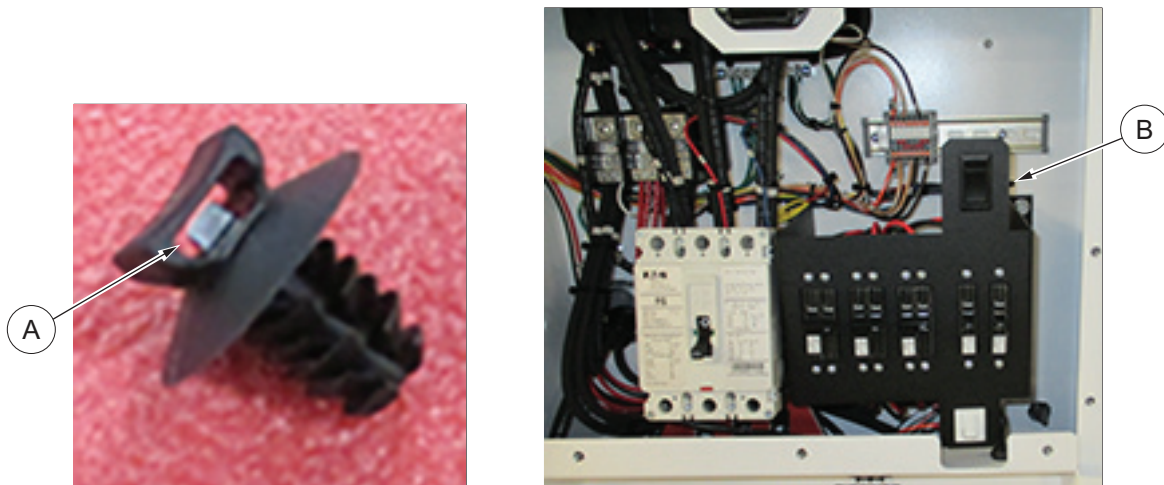

**Figure 21 - Location of Drill-Hole**

Item	Description
A	Location of drill-hole, interior view
B	Location of drill-hole, view from control box

- c. See [Figure 22](#). Insert (but do not fasten) cable-tie (PN 19400) in cable-tie mount (PN 66685). Install cable-tie mount in pre-existing hole in wall of control box, as shown.

**Note:** Do not fasten cable-tie at this time.

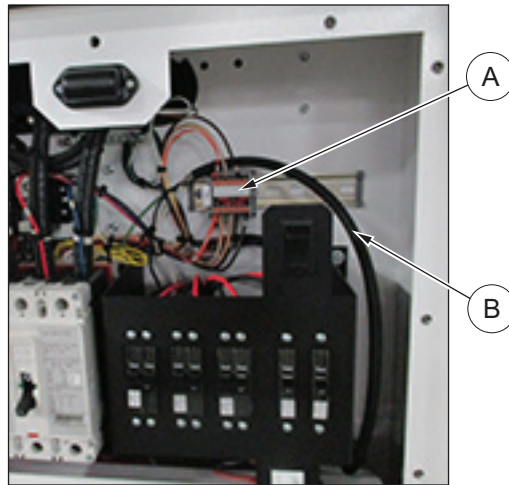

**Figure 22 - Cable-Tie Mount, Install Location**

Item	Description
A	Cable-tie insertion point
B	Install location of cable-tie mount



d. See *Figure 23*. Route heater harness behind TB2 wires, as shown.



**Figure 23 - Correct Heater Harness Routing**

Item	Description
A	TB2 and wires
B	Heater harness

e. See *Figure 24*. Connect heater harness wires, as described below.

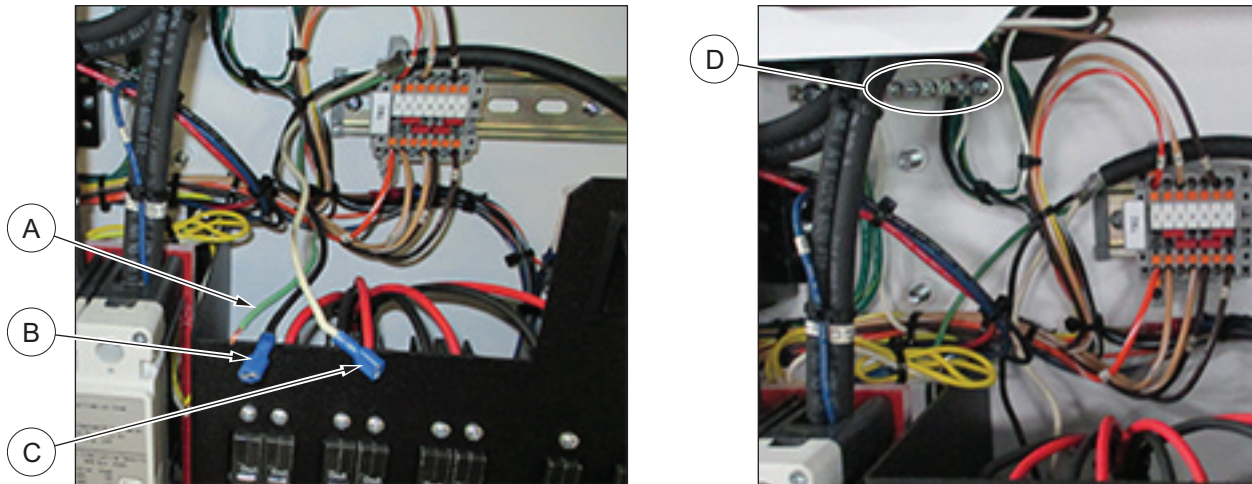

**Figure 24 - Heater Harness Wires and Ground Bar**

Item	Description	Connect To
A	Green heater harness wire	Ground bar
B	Black heater harness wire	Spade terminal on thermal switch harness (PN 68374)
C	White heater harness wire	Spade terminal on fuse assembly (PN 68864)
D	Ground bar	Green heater harness wire

- f. See *Figure 25*. Route wires to terminal blocks. Connect as follows.

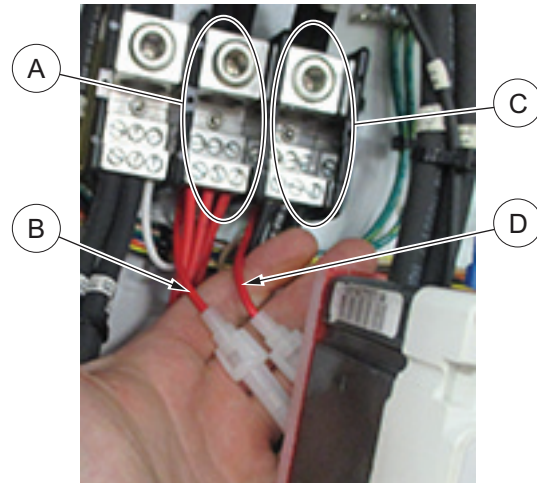

**Figure 25 - Correct Wire-Routing to Terminal Block**

Item	Description
A	T9 terminal block
B	Fuse assembly wire
C	T7 terminal block
D	Thermal switch harness wire

- Connect fuse assembly wire to a terminal on **T9**
  - Connect thermal switch harness wire to a terminal on **T7**
- g. See *Figure 26*. Secure heater harness to cable-tie mount by fastening the cable-tie. Trim cable-tie.

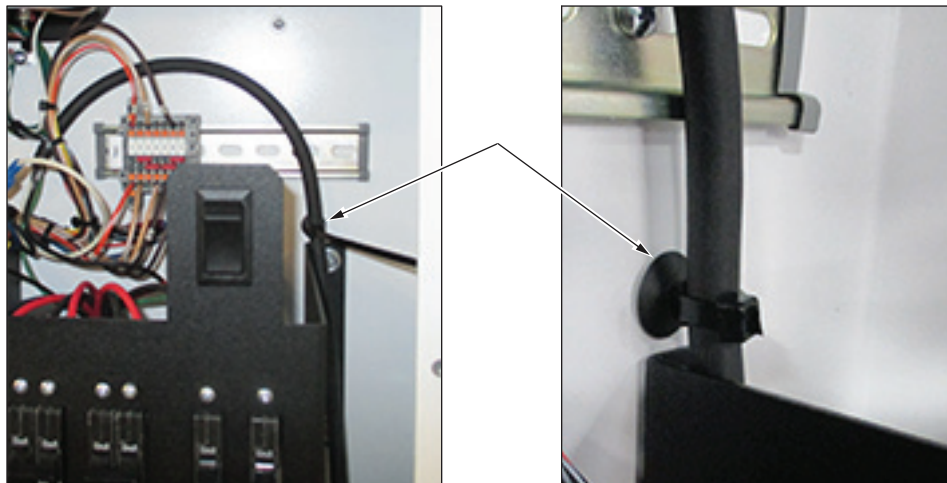

**Figure 26 - Heater Harness, Secured to Cable-Tie Mount**

h. See *Figure 27*. Position thermostat, as shown. Secure with cable-tie.

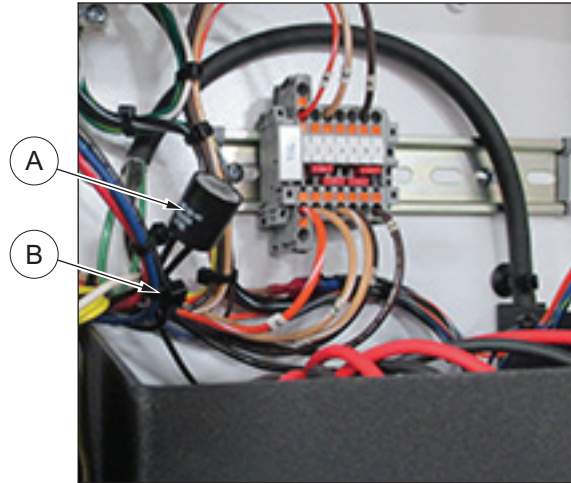

**Figure 27 - Thermostat, Correctly Secured**

Item	Description
A	Thermostat
B	Cable-tie

i. Install control box panels using original hardware (retained in step 23a).

24. Connect negative battery cable to negative battery terminal.